

USB-power module

This is a very simple board performing the following functions:

- USB B socket (main USB (slave) and +5V power)
- USB A socket (for USB host)
- Toggle switch for USB host
- 3.5mm jack for footswitch/gate or other input/output (audio?)
- Headers to draw +5V directly off the USB power buss.

Schematic

Both USB connectors are wired to the 1*5 J1 header via low-value resistors. There is a TVS diode on the underside that should help a bit with ESD. One side of the toggle switch sets the ID pin low, meaning the Core should respond as a USB host. In this case, it is expected that the USB B socket supplies power only. The host port would then be the USB A socket. J7 must be closed to supply power from the main USB buss to any slave device on the USB A side. If the slave has its own power supply, then leave J7 open.

Headers J3-6 are wired to +5V, so this is a good point to connect power-hungry parts like displays or LEDs.

The left-hand side connects to the 3.5mm socket. The idea is to use the tip of a stereo jack as an interface to a gate (i.e. from a modular synth). As the DIN pins normally expect negative-going signals, the classic S-trig converter is applied:

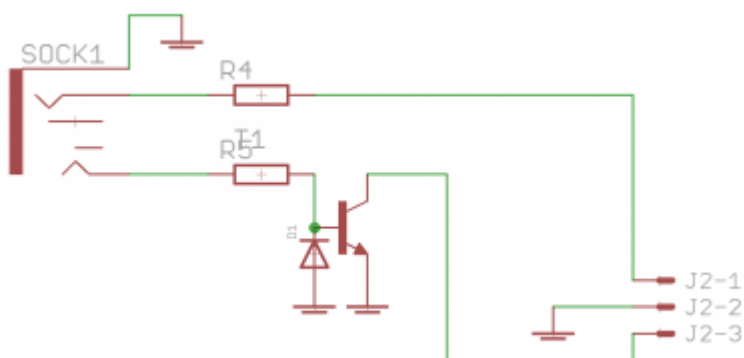

To use the socket for another purpose (audio input or output?), feel free to omit the diode and transistor, and to bridge the collector and base pins.

The ring of the socket is for a normal footswitch closing to 0V/ground and there is a protection resistor in series.

BOM v1.0

Please find the current BOM on <http://midiphy.com>. The table below is deprecated and

will not be updated.

Type	Qty	Value	Package	Parts	Mouser	Reichelt	Conrad	Other	Notes
Resistors									
	2	22R 5%	1206	R1, R2					
	1	330R 5%	1206	R3					
	2	10k 5%	THT	R4, R5					
Diodes									
	1	1N4148	THT						
	1	TVS	SOT-143	TVS1	PRTR5V0U2X,215				
Transistor									
	1	BC337	TO-92	T1					
Switch									
	1	SPDT		SW1	1101M2S3AV2BE2	SS 13LSP			Mouser one is better quality
					1101M2S4AV2BE2				Longer actuator (recommended).
Headers									
	1	1*2	male						
	5	1*3	male						
	1	1*5	male						or wire directly
Sockets									
	1	USB B	horizontal	USB1	538-67068-7041	USB BW			
	1	USB A	upright	USB2	538-89485-8000				
	1	3.5mm		SOCK1	CUI SJ1-3535NG				other variants are possible (different pins switched etc.)
Hardware									
	2	M3 PCB mount		534-7695					

Versions

v1.0: first release.

Assembly

Solder the SMT parts first. Ensure the TVS diode is aligned with the larger pin on the larger pad and that the wide edge of the body fits between the silkscreen indicators:

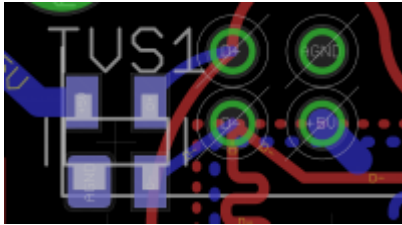

Note this is the board viewed from the bottom; the larger pin is on the bottom-left.

To have a through-hole USB A socket, the pins are quite close together. Be careful to avoid bridges when soldering and **test with a multimeter to ensure no adjacent pins are connected afterwards!**

It goes without saying, but ensure none of the metal parts are touching (e.g. the outside of the USB sockets with J7, the 1N4148 diode with the mounting brackets etc.).

License

Currently the design is © 2017 antilog devices with all rights reserved; all documentation is CC BY-NC-SA 3.0.

From:

<http://www.midibox.org/dokuwiki/> - **MIDIbox**

Permanent link:

http://www.midibox.org/dokuwiki/doku.php?id=wcore_usb

Last update: **2018/12/18 09:36**

